

CARATTERISTICHE TECNICHE | DATA SHEET
 DONNÉES TECHNIQUES | TECHNISCHE DATEN

SALUMERIA 280-315-360

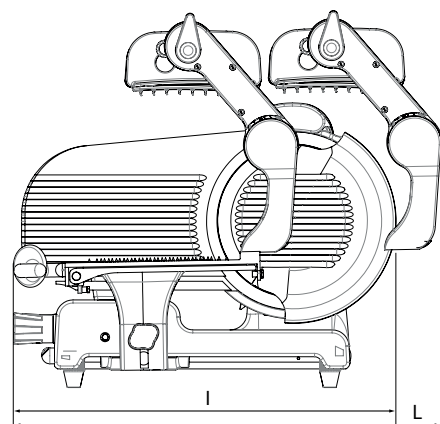
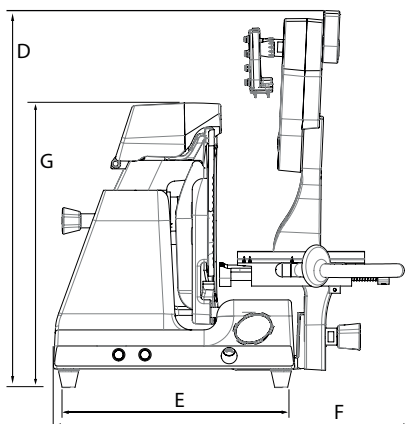
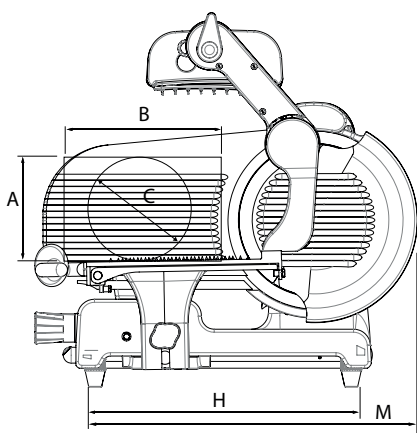

	SPECIFICHE SPECIFICATIONS SPÉCIFICATIONS TECHNISCHE MERKMALE			DIMENSIONI DIMENSIONS MASSE		
	FTS280	FTS315	FTS360	FTS280	FTS315	FTS360
∅ Lama ∅ Blade ∅ lame ∅ Messer	280 mm	315 mm	360 mm	A 190 mm	A 200 mm	A 245 mm
Capacità di taglio circolare Capacity (circle) Capacité (cercle) Leistung (Kreis)	215 mm	245 mm	275 mm	B 252 mm	B 285 mm	B 310 mm
Capacità di taglio rettangolare Capacity (rectangle) Capacité (rectangle) Leistung (Rechteck)	265x190h mm	285x200h mm	310x245h mm	C 215 mm	C 245 mm	C 275 mm
Spessore taglio Cut thickness Epaisseur de coupe Schnittbreite	0 - 17 mm	0 - 17 mm	0 - 17 mm	D 600 mm	D 640 mm	D 620 mm
Peso netto Net weight Poids net Nettogewicht	34 kg	40 kg	46 kg	E 325 mm	E 375 mm	E 420 mm
Potenza motore Motor rating Puissance moteur Motorleistung	0,18 - na kW	0,24 - 0,27 kW	0,55 - 0,55 kW	F 550 mm	F 610 mm	F 758 mm
Specifiche elettriche Electrical specifications Caractéristiques électriques Elektrische Eigenschaften	V - Hz 230/50 /1 400/50/3	V - Hz 230/50 /1 400/50/3	V - Hz 230/50 /1 400/50/3	G 450 mm	G 515 mm	G 560 mm
Disponibile anche con Available also with Aussi disponible avec Verfügbar auch mit	110 V 60 Hz	110 V 60 Hz	110 V 60 Hz	H 413 mm	H 435 mm	H 535 mm
				I 665 mm	I 730 mm	I 830 mm
				L 745 mm	L 820 mm	L 880 mm
				M 570 mm	M 640 mm	M 690 mm

Nota: A seguito della continua ricerca per migliorare sempre i nostri prodotti, le specifiche tecniche sono soggette a possibili variazioni
 Note: As we actually strive to improve our products, specifications are necessarily subject to change without notice
 Remarque: En raison de la recherche continue pour améliorer nos produits, les spécifications techniques sont sujettes à des possibles variations
 Anmerkung: Aufgrund der ständigen Forschung für die Verbesserung unserer Produkte, die Produktionsvorgabe können Änderungen zeigen