

CE



centrostampaschio.com



sunmix
NEW GENERATION MACHINES

SPIRAL MIXER
TOP LINE



Sunmix Srl
Via Lago di Vico, 4 - 36015 Schio (VI) Italy
Tel. +39 0445 640559 - info@sunmix.it
P. IVA / C.F. 04250510247 - www.sunmix.it



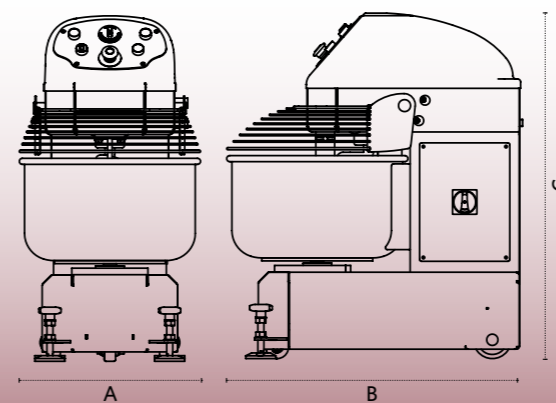

DATI TECNICI
TECHNICAL SPECIFICATIONS
CARACTERISTIQUES TECHNIQUES
DATOS TÉCNICOS

1 motore/1 motor 230V | 50-60Hz | 1Ph



ROSSO RUBINO



NERO PROFONDO



BIANCO PURO

Modello Model Modèle Modelo	Capacità impasto Dough capacity Capacité de pâte Capacidad de masa kg	Capacità farina Flour capacity Capacité de farine Capacidad de harina kg	Volume vasca Bowl volume Volume de la cuve Volumen cava lt	Potenza motore Motor power Puissance du moteur Potencia motore kw	Velocità Speed Vitesse Velocidad	Peso Weight Poids Peso kg	Dimensioni / Dimensions Dimensions / Dimensiones		
							A cm	B cm	C cm
SUN30 TL A	30	18	45	2.2	70/210	160	48	80	102
SUN40 TL A	40	22	55	2.2	70/210	165	54	85	102
SUN50 TL A	50	26	67	3	70/210	210	54	95	110

*Capacità di impasto calcolata su un'idratazione del 60% / *Dough capacity calculated on a 60% hydration / *Capacité de pâte calculée sur 60% d'hydratation / *Capacidad de masa calculada sobre una hidratación del 60%

I

CARATTERISTICHE TECNICHE:

- Capacità di impasto da 30 a 50 kg.
- Macchina semplice, robusta e affidabile studiata per contenere i costi garantendo ottime prestazioni.
- Con motore monofase con inverter.
- Velocità 70/210 rpm.
- Spirale rinforzata, vasca pane, spezza pasta calibrato.
- Pannello comandi nella parte superiore della macchina.
- Ruote a scomparsa di serie.
- Vasca, spirale, piantone in acciaio inox ad alta resistenza.
- Riparo in acciaio su tutta la gamma.
- Trasmissione su cuscinetti a sfera pre-lubrificati.
- Verniciatura con polveri epossidiche atossiche per alimenti.
- Impianti elettrici e dispositivi di sicurezza secondo le norme CE.
- Colori standard: Rosso rubino, Nero profondo, Bianco puro (altri colori su richiesta).

OPTIONAL:

- 300 RPM
- Luci per illuminare l'impasto.
- Voltaggio speciale.

EN

TECHNICAL SPECIFICATIONS:

- Mixing capacity from 30 to 50 kg.
- A simple, robust and reliable machine designed to ensure optimum performance.
- With single-phase motor with inverter.
- Speed 70/210 rpm.
- Reinforced spiral, bread bowl, calibrated dough cut column.
- Control panel at the top of the machine.
- Retractable castors.
- High resistance stainless steel bowl, spiral arm and breaking bar.
- Stainless steel safety guard.
- Pre-lubricated ball bearing transmission.
- Non-toxic powdered epoxy certified coating.
- Electrical system and safety devices realised in accordance with CE regulation.
- Standard colors: Rosso rubino, Nero profondo, Bianco puro (other colors upon request).

OPTIONAL:

- 300 RPM
- Lights to illuminate dough.
- Special voltage.

F

CARACTÉRISTIQUES TECHNIQUES:

- Capacité de pâte de 30 à 50 kg.
- Avec moteur monophasé avec onduleur.
- Vitesse 70/210 rpm.
- Spirale renforcée, bol à pain, colonne de coupe calibrée de pâte.
- Panneau de commande en haut de la machine.
- Roues escamotables.
- Cuve, spirale, soc diviseur en acier inoxydable hautement résistant.
- Grille de protection en acier inoxydable.
- Système de transmission à roulements à bille lubrifiés par bain d'huile.
- Peinture réalisée en poudre époxy spéciale alimentaire.
- Installation électrique et dispositifs de sécurité conformes aux normes européennes.
- Couleurs standards: Rosso rubino, Nero profondo, Bianco puro (autres coloris sur demande).

OPTIONAL:

- 300 RPM
- Lumières pour éclairer la pâte.
- Tension spéciale.

ES

CARACTERÍSTICAS TÉCNICAS:

- Capacidad de amasado de 30 a 50 kg.
- Con motor monofásica con inductor.
- Velocidad 70/210 rpm.
- Espiral reforzada, bol de pan, columna central calibrada.
- Panel de control en la parte superior de la máquina.
- Ruedas estándares.
- Cava, espiral, protección de acero inoxidable de alta resistencia.
- Protección de artesa de acero en toda la gama.
- Transmisión mediante cojinetes de esfera prelubricados.
- Pintado con polvos epoxidicos atóxicos para alimentos.
- Instalación eléctrica y dispositivos de seguridad según normas CE.
- Colores de serie: Rosso rubino, Nero profundo, Bianco puro (otros colores a pedido).

OPTIONAL:

- 300 RPM
- Luces para iluminar la masa.
- Voltaje especial.